



SIN 345

Issue 1.5
March 2009

Suppliers' Information Note

For The BT Network

BT CHANNEL EXTENSION SERVICE 1000

Service Description

Each SIN is the copyright of British Telecommunications plc. Reproduction of the SIN is permitted only in its entirety, to disseminate information on the BT Network within your organisation. You must not edit or amend any SIN or reproduce extracts. You must not remove BT trade marks, notices, headings or copyright markings.

This document does not form a part of any contract with BT customers or suppliers.

Users of this document should not rely solely on the information in this document, but should carry out their own tests to satisfy themselves that terminal equipment will work with the BT network.

BT reserves the right to amend or replace any or all of the information in this document.

BT shall have no liability in contract, tort or otherwise for any loss or damage, howsoever arising from use of, or reliance upon, the information in this document by any person.

Due to technological limitations a very small percentage of customer interfaces may not comply with some of the individual characteristics which may be defined in this document.

Publication of this Suppliers' Information Note does not give or imply any licence to any intellectual property rights belonging to British Telecommunications plc or others. It is your sole responsibility to obtain any licences, permissions or consents which may be necessary if you choose to act on the information supplied in the SIN.

This SIN is available in Portable Document Format (pdf) from: <http://www.sinet.bt.com/index.htm>

Enquiries relating to this document should be directed to: help@sinet.bt.com

CONTENTS

1. INTRODUCTION.....	3
2. SERVICE OUTLINE	3
3. CUSTOMER INTERFACE	3
3.1 CONNECTOR.....	4
3.2 TRANSMISSION.....	4
3.3 NETWORK LINK BREAK	4
4. POWER SUPPLY	4
5. CUSTOMER APPARATUS DESIGN/INSTALLATION ADVICE.....	5
6. TECHNICAL SPECIFICATION.....	5
7. FURTHER INFORMATION	5
8. REFERENCES.....	5
9. ABBREVIATIONS	6
10. HISTORY	6
ANNEX A. POSSIBLE USES OF THE CES 1000 BASIC BUILDING BLOCK.....	7
A.1 CES 1000A.....	7
A.2 CES 1000B.....	8

1. Introduction

This Suppliers Information Note (SIN) describes the BT Storage Area Network (SAN) Fibre Channel Extension Service 1000 (CES 1000). The SIN also provides information about the service for use by Customer Premises Equipment (CPE) manufacturers and developers.

NB - The BT Global service described in this SIN is now delivered using Openreach Wholesale End to End Extension Service 1000 (WEES 1000), which is described in SIN 436. However, this SIN 345 remains available for reference.

2. Service Outline

The CES 1000 service operates at a speed of 1.062Gbit/s in full duplex mode at a radial distance of up to 25km between customer's sites. For enquiries concerning connection availability between particular sites and for further information on the CES 1000 service please contact the Data Connect Helpdesk, using the contact details at <http://www.sinet.bt.com/usenum.htm>. Possible uses of the CES 1000 service are shown below.

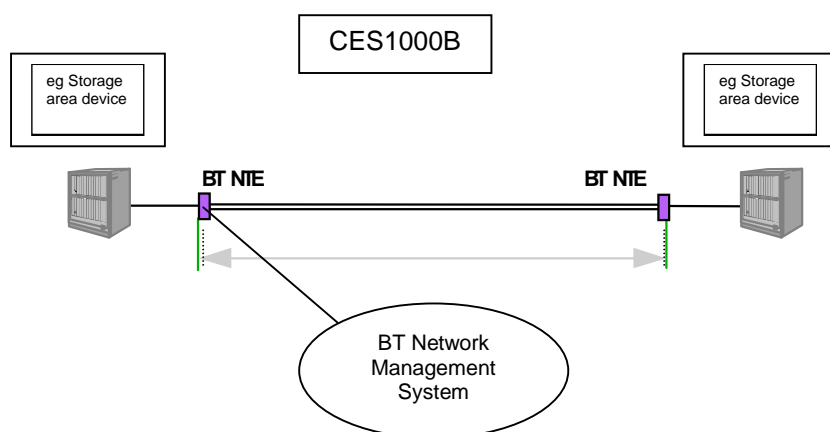

Figure 1 Typical CES 1000 service configuration

It is intended that customers will use this service for the interconnection of Storage Area Networks (SAN), Data Centres incorporating a Fibre Channel backbone, and/or disaster recovery availability when mirroring two storage areas with Fibre Channel connections.

3. Customer Interface

Fibre channel is commonly used for building 100 MBps storage area networks (SAN). In SAN configurations, Fibre Channel allows separation of storage devices from servers. Data is a critical business asset, and many businesses are using Fibre Channel to build business continuance (disaster recovery) SAN's that span a metropolitan area.

3.1 Connector

The interface is the Network Termination Point (NTP), i.e. the point of connection between the BT Network Terminating Equipment (NTE) and the CPE interface.

The customer interface consists of a Dual SC type fibre interface port which may be either short-wave (850nm) multimode **OR** long-wave (1310nm) singlemode (not both on a single NTE). The type of customer interface required must be specified at time of order. The customer provides the fibre patch connectors between the NTE and CPE.

The maximum fibre length between the NTE and customer equipment is 500metres for short-wave (850nm multimode) ports when 50/125 micron optical patch cords are used or 220metres if 62.5 micron optical patch cords are used. For long-wave (1310nm single-mode) ports, the maximum fibre length is 10km.

The dual SC type connector is as specified by ANSI/INCITS Fibre Channel ^[1] standards. Attention is drawn to the Intellectual Property Rights (IPRs) set out in the preface of this agreed International standard. It is the responsibility of the CPE supplier to ensure that they have the necessary rights from the owner of the IPR. The IPR owner has stated that they are willing to negotiate licences under reasonable and non-discriminatory terms and conditions with applicants throughout the world.

3.2 Transmission

The NTE is capable of transporting data at 1.062 Gbit/s (Fibre Channel baud rate). The NTE retimes the data passing through it. The retiming process controls jitter at the customer port output on the NTE. Retiming is required for a device to be fully compliant with Fibre Channel specification^[1].

The NTE does not have the capability to intercept and/or view 'customer data'.

3.3 Network Link Break

When a fibre break is detected on the network link, a specific 8B/10B code is continuously transmitted on the customer interface to indicate the fibre state. This continues until such time as the fibre break is repaired. The control code transmitted under this fibre fault condition is K28.5.

4. Power supply

Adjacent 13 Amp socket outlets supplying 230V a.c. 50Hz are required to power the NTE. At new installations, the power consumption will not normally exceed 30 Watts per CES 1000 circuit.

5. Customer Apparatus Design/Installation Advice

CES 1000 service has been designed such that any vendor's Fibre Channel device that has ANSI FC-PI compatible interfaces of the short-wave (850nm) or long-wave (1310nm) variety, will be able to connect to each NTE.

6. Technical Specification

Protocol	Fibre Channel, ANSI/INCITS 352-2002
Data Format	8B/10B
Line Rate	1.062 Gbit/s
Power Requirement	Mains voltage 50 Hz AC input
Customer Fibre Connector	Dual SC (as defined by FC-PI)
Short-Haul Fibre Cable <i>Customer provided</i>	Multimode 850nm, 50/125 or 62.5/125 micron
Short-Haul Fibre <i>Maximum Delivery Distance</i>	500m from NTE's multimode port using 50/125 micron fibre or 220m using 62.5micron fibre
Long-Haul Fibre Cable <i>Customer provided</i>	Single-mode 1310nm, 9/125 micron
Long-Haul Fibre <i>Maximum Delivery Distance</i>	10Km from NTE's single-mode port
Operating Temperature	0 to 40 °C
Laser Safety	Class 1 under all conditions as per IEC 825-1

7. Further Information

For "sales and marketing" information on the CES 1000 service, please contact either:

- Your Company's BT account manager
- For customers who do not have an account manager, please contact BT sales on 0800 800152 for product and service information, sales and rental enquiries.

8. References

ANSI/INCITS Standards:

[1]	ANSI/INCITS 352-2002	Information technology - Fibre Channel - Physical Interfaces (FC-PI)
-----	----------------------	--

To purchase copies of the referenced documentation please contact either the British Standards Institute or Technical Indexes Ltd. Contact details for these organisations are given on the documents sources page at <http://www.sinet.bt.com/usenum.htm#docsources>.

9. Abbreviations

ANSI	American National Standards Institute
CES	Channel Extension Service
CPE	Customer Premises Equipment
FC-PI	Fibre Channel - Physical Interface
INCITS	InterNational Committee for Information Technology Standards
IPRs	Intellectual Property Rights
Mbit/s	Megabits per second
MBps	Megabytes per second
NTE	Network Terminating Equipment
NTP	Network Terminating Point
SAN	Storage Area Network
SIN	Suppliers' Information Note

10. History

Issue 1	June 2000	First Issue
Issue 1.1	January 2002	Editorial changes
Issue 1.2	June 2003	Clause on terminal approval requirements removed. Distances from NTE to CPE clarified for each multimode fibre type. Jitter control description clarified. "Link failure" text in clause 3 replaced by addition of clause 3.3 "Network Link Break". Line rate corrected to 1.062Gbit/s in Service Outline. ANSI/INCITS reference updated to 352-2002.
Issue 1.3	August 2004	"route distance" corrected to be "radial distance" in Service Outline clause.
Issue 1.4	February 2005	Information that CES 1000A is no longer available for new supply added to Annex A.
Issue 1.5	March 2009	Noted that the service is now delivered using Openreach WEES 1000, as described in SIN 436. Contact points also updated.

We would be grateful if you would spend a few minutes to complete an online customer satisfaction form at <http://www.sinet.bt.com/happy.htm>

Annex A. Possible uses of the CES 1000 basic building block

A.1 CES 1000A

CES 1000A offers point-to-point connectivity between two sites using two CES 1000B generic building blocks, the two blocks being installed at the same time. See Figure A.1.

Please note that the CES 1000A service is no longer available for new supply.

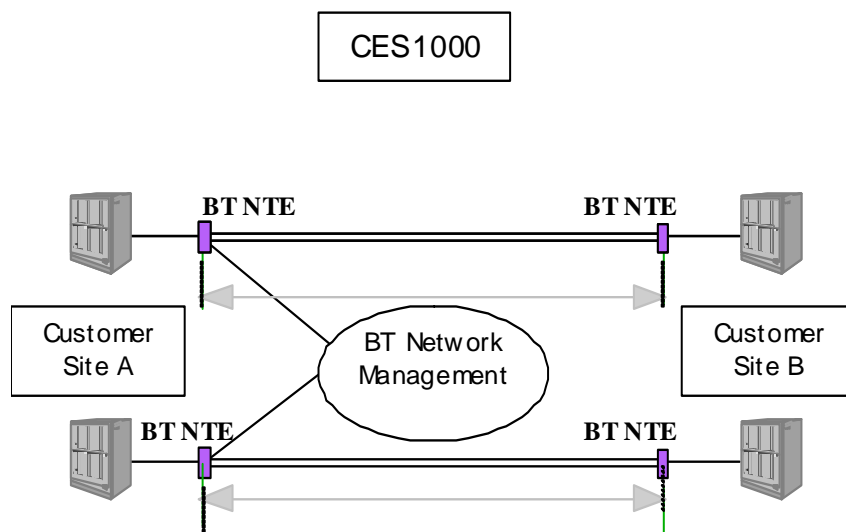

Figure A.1

A.2 CES 1000B

CES 1000B offers point-to-point connectivity between two or more sites using the basic building block between each pair of sites.

Where three or more sites are connected the customer has the opportunity to programme their CPE such that should there be a failure of one of the circuits the CPE will route traffic over the other circuits to the correct destination. As an example, in Figure A.2 if circuit 1 should fail traffic would be routed via circuits 2 and 3.

Figure A.2

