



SIN 452

Issue 1.0

November 2005

Suppliers' Information Note

For The BT Network

Wireless Symmetric Broadband Service Description

Each SIN is the copyright of British Telecommunications plc. Reproduction of the SIN is permitted only in its entirety, to disseminate information on the BT Network within your organisation. You must not edit or amend any SIN or reproduce extracts. You must not remove BT trade marks, notices, headings or copyright markings.

This document does not form a part of any contract with BT customers or suppliers.

Users of this document should not rely solely on the information in this document, but should carry out their own tests to satisfy themselves that terminal equipment will work with the BT network.

BT reserves the right to amend or replace any or all of the information in this document.

BT shall have no liability in contract, tort or otherwise for any loss or damage, howsoever arising from use of, or reliance upon, the information in this document by any person.

Due to technological limitations a very small percentage of customer interfaces may not comply with some of the individual characteristics which may be defined in this document.

Publication of this Suppliers' Information Note does not give or imply any licence to any intellectual property rights belonging to British Telecommunications plc or others. It is your sole responsibility to obtain any licences, permissions or consents which may be necessary if you choose to act on the information supplied in the SIN.

This SIN is available in Portable Document Format (pdf) from: <http://www.sinet.bt.com>

Enquiries relating to this document should be directed to: help@sinet.bt.com

CONTENTS

1.	INTRODUCTION.....	3
1.1	GENERAL	3
1.2	DEFINITIONS	3
2.	WIRELESS SYMMETRIC BROADBAND: SERVICE OUTLINE	3
3.	ACCESS PRODUCT	4
3.1	WIRELESS SYMMETRIC BROADBAND END-USER INSTALLATION	4
4.	HANDOVER PRODUCTS	5
4.1	SP HANDOVER ARCHITECTURE: PRIVATELY PEERED CUSTOMER	5
4.2	SP HANDOVER ARCHITECTURE: INTERNET PEERED CUSTOMER	6
4.3	CUSTOMER INFORMATION	7
5.	INTERFACE TECHNICAL SPECIFICATION	7
5.1	TRANSPORT IP LAYER.....	7
5.2	L2TP LAYER.....	8
5.3	PPP LAYER	8
5.3.1	<i>Tunnel parameters.....</i>	<i>9</i>
5.4	SESSION TIMEOUTS	9
5.5	END USER CPE	9
5.6	PPPoE CONSIDERATIONS	9
6.	AVAILABILITY.....	10
7.	CONFIGURATION OF THE SERVICE	10
7.1	SESSION ESTABLISHMENT	10
7.2	IP ADDRESSING	11
7.3	RADIUS AUTHENTICATION	11
7.3.1	<i>Access Request packet attributes.....</i>	<i>11</i>
7.3.2	<i>Access Accept packet attributes.....</i>	<i>12</i>
7.4	RADIUS ACCOUNTING	12
8.	REFERENCES.....	13
9.	ABBREVIATIONS	14
10.	HISTORY	15

FIGURES

FIGURE 1.	BASIC ARCHITECTURE SUPPORTING THE WIRELESS SYMMETRIC BROADBAND SERVICE	3
FIGURE 2.	ACCESS PRODUCT COMPONENTS	5
FIGURE 3.	HANDOVER ARCHITECTURE FOR A PRIVATELY PEERED CUSTOMER	5
FIGURE 4.	HANDOVER ARCHITECTURE FOR AN INTERNET PEERED CUSTOMER	6
FIGURE 5.	STAGES OF PPP SESSION AND L2TP TUNNEL ESTABLISHMENT	8

TABLES

TABLE 1.	ACCESS REQUEST PACKET ATTRIBUTES	12
TABLE 2.	ACCESS ACCEPT PACKET ATTRIBUTES	12

1. Introduction

1.1 General

This Suppliers' Information Note describes the characteristics of the Access and L2TP Handover interfaces available for the Wireless Symmetric Broadband service. It does not apply to any other service, or for Customers serving End Users outside Lincolnshire. The service is offered subject to availability. Other BT services may provide a different form of L2TP interface.

1.2 Definitions

Customer – The Service Provider (SP) who purchases the Wireless Symmetric Broadband service from BT and sells or provides it to End Users.

End User – A subscriber who connects to a Customer's network via the Wireless Symmetric Broadband service.

LNS – L2TP Network Switch. A network device (router) which terminates End User PPP sessions (also known as a Home Gateway).

LTS – L2TP Tunnel Switch. A network device (router) which switches L2TP tunnels containing End User PPP sessions to a designated LNS.

2. Wireless Symmetric Broadband: Service Outline

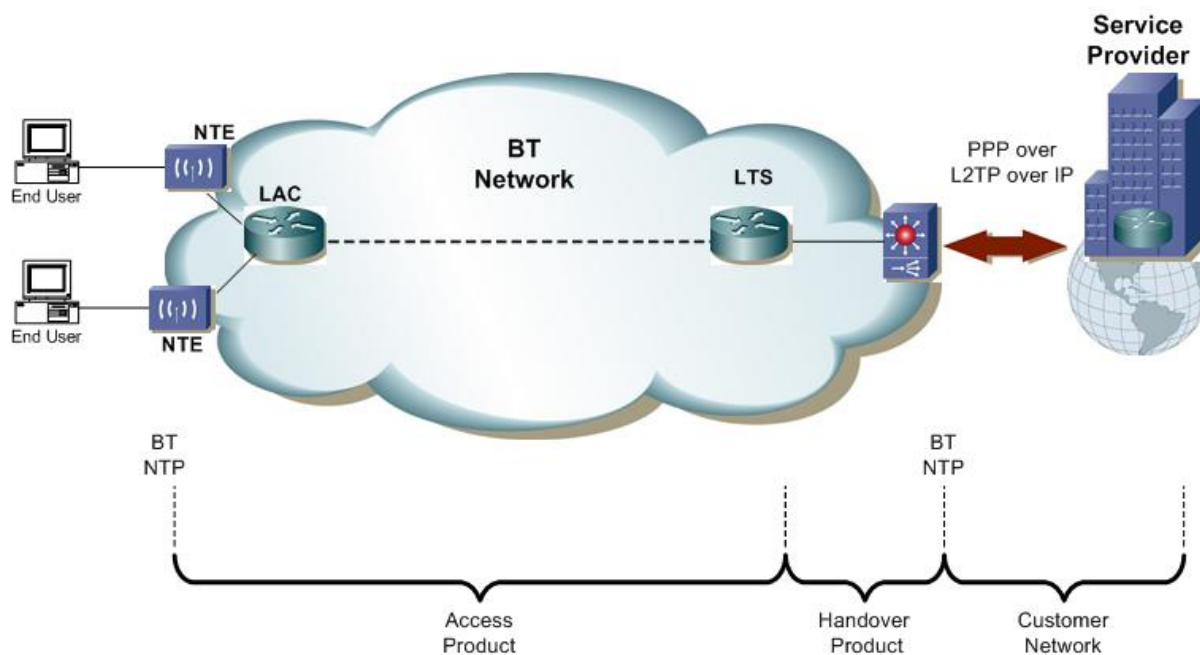

Figure 1. Basic Architecture supporting the Wireless Symmetric Broadband service

Wireless Symmetric Broadband enables a Customer to access multiple End Users via an IP network. The Customer owns the sales, marketing and recruitment of End Users and the contractual/service relationship. BT supplies the delivery transport and basic service.

The Service comprises an access product and a choice of two Customer handover options. For end-to-end connectivity a Customer will require at least one handover product and at least one access product. The access product provides IP connectivity from an End User to a central aggregation point. The handover products provide onward IP connectivity to an LNS router in the Customer network.

3. Access Product

The access product provides contended IP over PPP connections from the Customer's End Users over dedicated L2TP tunnels to a designated handover point. This comprises of the wireless local loop and appropriate backhaul to the handover point. Onward connection to the Customer network is provided by switching the L2TP tunnels either over the Internet or directly to a router hosted and managed by the Customer.

One access product is required per End User.

The access product provides the following:

- PPPoE End User connection (client required)
- Up to 2Mbit/s symmetric
- 10baseT Ethernet (IEEE 802.3⁽¹⁾) connection to the End User
- 10:1 contention ratio
- Single MAC address presentation per End User
- Single PPPoE session per End User
- Wireless access restricted to PPP traffic only

The data rate is defined as the rate available for the transport of IP packets over the wireless segment of the network. Note that each IP packet will also incur TCP/IP and PPPoE overhead. The effective IP throughput may vary depending on the average packet size and local network conditions.

3.1 Wireless Symmetric Broadband End-User Installation

The access product includes a 5.8GHz wireless bridge subscriber unit with an RJ45 wired Ethernet interface. Note that BT will provide the RJ45 crossover cable required to connect a PC or router to the NTE. Additional RJ45 fly leads, routers, USB converters, etc are *not* included unless by specific agreement.

The wireless subscriber unit consists of an externally mounted antenna unit with a wired connection to an internal unit. The End User PC or router connects to the NTP on the indoor unit at an Ethernet 10baseTx (RJ45) interface. The cable between the external and internal components is included within the access product.

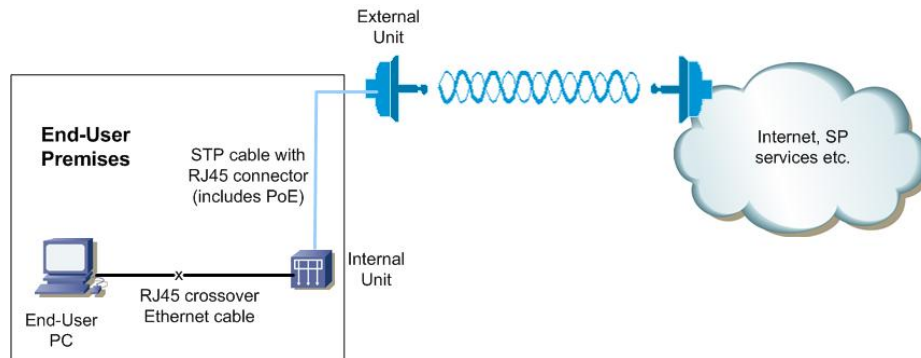

Figure 2. Access Product Components

BT will commission the wireless subscriber unit equipment and will retain control of the in-life configuration. Customers and End Users will not have configuration access to either the internal or external subscriber unit equipment. BT are unable to accept responsibility for any loss of service resulting from Customer or End User attempts to access or reconfigure the subscriber unit. Further information can be found in the Terms and Conditions for the service.

4. Handover Products

The SP handover allows Customers direct access to their End Users' PPP sessions. These PPP sessions are presented to the Customer in L2TP tunnels over a routed IP interface. The LTS serves to isolate the Wireless Symmetric Broadband network from the Customer network. It marks the last point at which the service can be managed by BT.

BT recommend that customers select a single handover option for all End Users. It is not possible to co-present Wireless Symmetric Broadband connections via any existing BT xDSL handover product (e.g. IPStream Central or Central+).

4.1 SP handover architecture: Privately Peered Customer

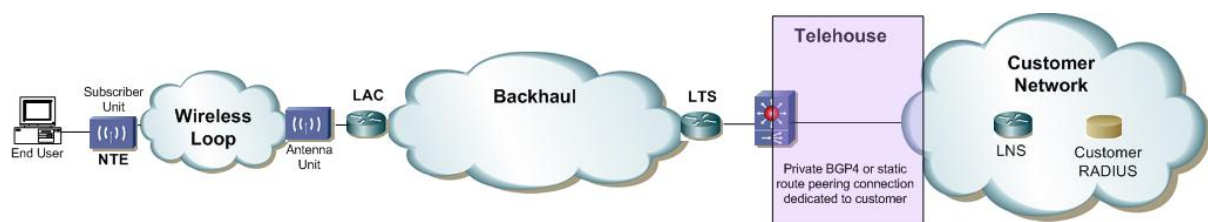

Figure 3. Handover architecture for a privately peered customer

A private, routed IP connection will be made by the SP from their equipment and accommodation to the BT equipment.

L2TP tunnel(s) containing all End User PPP connections for the Customer are switched by an LTS router within the BT network to an LNS or LTS router in the Customer network. The Customer retains control of PPP sessions for their End Users. Traffic is presented to the Customer at the Interconnect point as L2TP over IP over Ethernet. The peak upstream and downstream rates for each end user are controlled within the BT network.

The Customer will provide an NTE router, suitable accommodation and an appropriate Ethernet connection to BT equipment installed at an independent co-location facility in Telehouse, London. This router should be capable of static or BGP4 routing, depending on the peering options selected. BT's preferred presentations are 10/100Tx Ethernet on Cat5 UTP cable or 1000SX Ethernet on multimode fibre. Other Ethernet presentations may be considered subject to availability. The demarcation point for the handover will be the egress interface of the BT Ethernet switch. The Customer should authenticate their End User access requests based on username and fully-qualified domain. BT cannot provide hosting facilities within their accommodation for Customer NTE equipment.

4.2 SP handover architecture: Internet Peered Customer

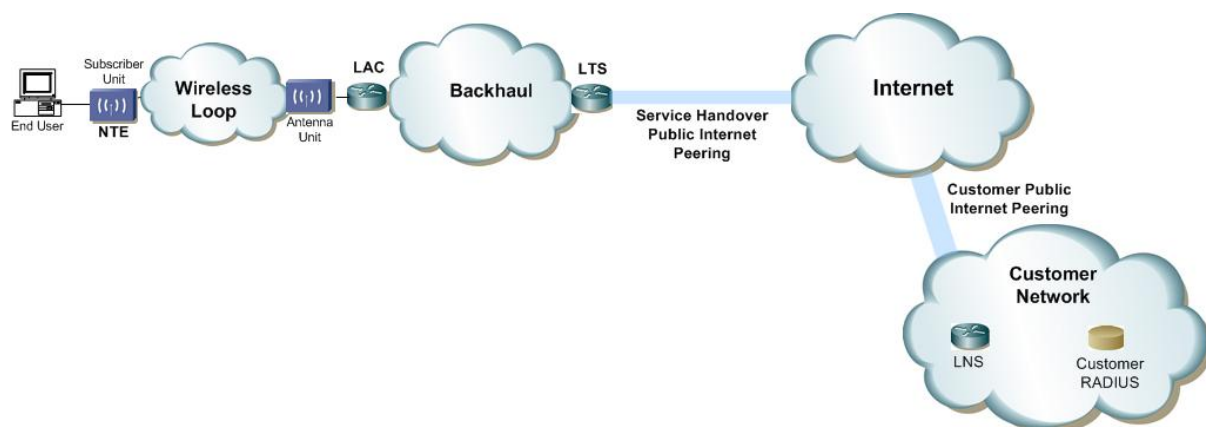

Figure 4. Handover architecture for an internet peered customer

L2TP tunnel(s) containing all End User PPP connections for the Customer are switched by an LTS router at the central site to an LNS or LTS router in the Customer network. The Customer retains control of PPP sessions for their End Users. Traffic is presented to the Customer at the Interconnect as L2TP over IP. The peak upstream and downstream rates for each end user are controlled within the BT network.

L2TP traffic will be switched over the public internet. Tunnels may be switched to any publicly visible IP address of the Customer's choosing. The demarcation point for the handover will be the egress interface from the BT network to the Internet.

The Customer will provide an LTS/LNS router with appropriate Internet connectivity and authentication of their End User access requests based on username and fully-qualified domain.

4.3 Customer information

The Customer must provide the following information to order the LTS interconnect:

- **IP addressing and routing information** (for private peering variant)
- **MD5 authentication key** (private-peering BGP handover variant only)
- **Loopback address on the BT LTS** (Private peering variant only). BT can provide these if requested.
- **Test user account on the Customer RADIUS** for end-to-end connectivity verification
- **IP address for each of the L2TP tunnel endpoints** (Internet peering variant or statically routed private peering only). LNS or LTS routers on the Customer-side of the interface
- **L2TP Tunnel Peer Name** (Optional). Name that the BT LTS should use when contacting the Customer LNS
- **L2TP Tunnel Password** that the BT LTS should use when contacting the Customer LNS
- **IP address and shared secret for Customer RADIUS server(s)** – only required if customer wishes to return L2TP tunnel information via RADIUS.
- **Domain name(s) to be used for the service**

Note: A test account allowing verification of the network connectivity up to and including the LTS will be made available to all Customers. This will provide access to a test web page and is intended to be used for installation and fault diagnostics.

5. Interface Technical Specification

The interface is End User PPP over L2TP over IP. In the private-peered variant this is delivered over a 10/100Tx RJ45 copper or 1000SX SC/LC fibre Ethernet interface. Both Customer and End User Ethernet interfaces comply with IEEE 802.3^[1].

5.1 Transport IP Layer

This layer must conform to RFC791^[2]. In the Internet handover variant there is no provision or requirement for a routing protocol to be used. The private-peered handover variant supports static routing or authenticated and filtered BGP4 routing protocol only.

5.2 L2TP Layer

Dynamic L2TP tunnels can be delivered to a maximum of four endpoints in the Customer network. Dynamic L2TP tunnels are opened on the first PPP session request and closed on the last session clear-down. All Customer equipment terminating L2TP tunnels must comply with RFC2661^[12] to ensure successful interworking.

The LTS will generally balance connections between multiple endpoints on a round-robin connection basis. This balancing is from the perspective of the Wireless Symmetric Broadband LTS only. It takes no account of the relative load on each endpoint from other services or sources internal or external to the BT network. A maximum of 8000 concurrent sessions is supported per Customer. This is an aggregate over all endpoints for that customer. Each endpoint can therefore receive a maximum of 8000/N concurrent connections, where N is the number of currently active endpoints. The Customer can choose whether to return L2TP tunnel information via RADIUS or have it statically configured on the BT network. The use of RADIUS allows the Customer steer sessions to their own devices as appropriate.

5.3 PPP Layer

The Customer terminating equipment must conform to RFC1661^[3], RFC1994^[4] and RFC 1877^[5] to ensure successful interworking. Authentication using Challenge Handshake Protocol (CHAP) will be requested during Link Establishment. The username and domain name captured from the End User PPPoE client and negotiated PPP parameters will be replayed from the LAC via the BT LTS to the Customer LTS/LNS equipment.

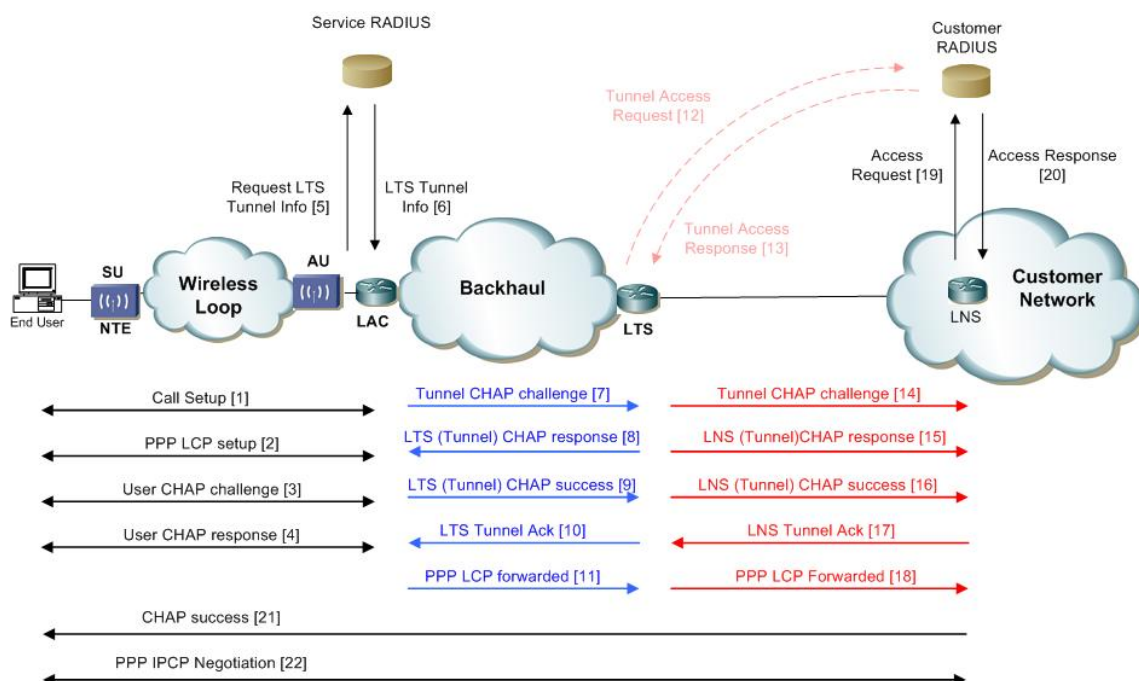

Figure 5. Stages of PPP session and L2TP tunnel establishment

Messages [1] and [2] are sent as a result of the End-User initiating a PPPoE session. The End-User client and the LAC router negotiate PPP LCP parameters. The LAC router initiates a request to the BT Service RADIUS to determine the details of the L2TP tunnel to be used for that session [5] & [6]. The LAC attempts to establish an L2TP tunnel to the LTS servicing that Customer [7] to [10] and on successful establishment forwards the LCP parameters negotiated with the client to the LTS [11]. The LTS in turn requests details of the LNS from the Customer RADIUS [12] & [13] and establishes an L2TP tunnel based on the information returned [14] to [17]. The negotiated LCP parameters are forwarded to the LNS [18]. The Customer LNS authenticates the End-User PPP session request against the Customer RADIUS [19] & [20]. Upon successful CHAP authentication a CHAP Success message is returned to the End-User [21] and IPCP negotiation is initiated. This will assign layer 3 protocol information such as IP address, DNS resolvers etc to the End-User [22].

5.3.1 Tunnel parameters

On request, *for Customers with a maximum of 3 LNS routers only*, the L2TP tunnel details can be pre-configured on the BT Service RADIUS. This removes any need for communication between BT and the Customer RADIUS. This may be of value in the Internet handover variant, where tunnel authentication via RADIUS must otherwise take place over the Internet. Pre-configuration of the Customer tunnel parameters removes steps [12] & [13] above.

Note: When using pre-configured tunnel parameters it is the Customer's responsibility to notify BT of any changes to relevant components of the Customer network which may affect end-to-end session establishment and service.

5.4 Session Timeouts

The Customer must enforce a minimum session timeout of 7200 seconds (2 hours) for both PPP idle and PPP session timeouts. This will ensure that PPP churn is minimised and in turn reduce the overhead on the network. An End User may manually terminate their session at any time. No maximum session timeout will be enforced.

5.5 End User CPE

The access product does not include End User CPE. The Customer has flexibility to specify their requirements regarding returning IP addresses, DNS resolver addresses etc. Any End User CPE provided by the Customer should comply with the appropriate RFCs (see § 5.6).

5.6 PPPoE considerations

The access product requires the use of PPPoE by the End User, regardless of the handover product. PPP[oE] and L2TP can add up to 40 bytes of overhead to transmitted packets. To avoid fragmentation and optimise the performance of the network it is recommended that Customers and End Users set their MTU at 1492 bytes.

PPPoE clients should be RFC2516^[6] and RFC1661^[3] compliant. If they are then the PPPoE client should be capable of sending an MRU of 1492 bytes to the LAC. The LAC in turn will

send an MRU of 1492 bytes to the client. If the client sends a larger MRU then they should agree on the lower value which the LAC will then proxy to the LTS/LNS.

If non-compliant then the PPPoE client and LAC may be unable to agree a valid MRU. Under these circumstances the LAC will do one of two things:

- Proxy an MRU-size of 1500 bytes to the Customer LNS (if the client has sent an MRU). This may in turn cause fragmentation which could affect throughput and performance.
- Send a default value of 1492 bytes (if the client does not send an MRU but agrees to the LAC's value).

If the End User machines are on a routed LAN (i.e. a CPE router is connected to the access product) then the IP MTU of all attached PCs should be set to 1492 or less. The Customer LNS should either be statically configured with an MTU of 1492 bytes or capable of renegotiating LCP end-to-end in the event of an MTU mismatch.

6. Availability

Wireless Symmetric Broadband products are only available in selected areas of Lincolnshire. The availability is independent of PSTN service, or xDSL exchange enablement.

During the initial order handling process, BT will survey the location of the End User to establish the suitability for Wireless Symmetric Broadband service and advise accordingly.

End Users may only receive a single Wireless Symmetric Broadband service over the wireless subscriber unit.

The provision of Wireless Symmetric Broadband and xDSL are not mutually exclusive.

Provision and operation of Wireless Symmetric Broadband will not affect the End User PSTN connection. PSTN connectivity (regardless of provider) is not a pre-requisite to Wireless Symmetric Broadband service provision.

For further information on service availability and tariffs please contact:

- For product and service enquiries please contact your BT Account Manager.
- For sales enquiries please contact BT Sales on 0870 240 1627 or email btwirelessaccess@niapollo.com.
- For further information please refer to www.btwirelessaccess.bt.com.

7. Configuration of the Service

7.1 Session Establishment

The Wireless Broadband equipment is configured to filter traffic, accepting only PPP packets from the End-User equipment. PPP is used to obtain IP addresses from the Customers address pool on a per-session basis. Note that only one session per End-User is permitted. Multiple sessions are not supported.

The End-User can establish a PPP session using client software or a CPE device. The End-User must provide their username, domain name and password.

7.2 IP addressing

IP addresses may be static, consistently served or be dynamically assigned to the End-User during the set-up phase of a PPP session. These addresses must be supplied by the Customer from pools on either the Customer RADIUS server or LNS router.

It is the Customer's responsibility to provide:

- IP addresses (registered appropriately)
- RADIUS server(s) - including support and administration

The Customer is able to assign any IP address from any range, excluding BT Management IP address ranges, to the End-User.

7.3 RADIUS authentication

End User authentication will be via a RADIUS mechanism at session set-up. The BT Service RADIUS server will authenticate the domain part of the Username, determine which BT LTS the End-User's Customer connects to and establish a tunnel to it (if one does not already exist for that Customer). The BT LTS then either requests information about which Customer LNS to use from the Customer RADIUS or uses statically configured tunnel parameters. Using this information the LTS switches the tunnel to the appropriate Customer LNS and passes the PPP session parameters via it.

Note: An L2TP tunnel is established during the first PPP session request to a Customer LNS. Subsequent session requests will use an existing tunnel where appropriate.

The Customer LNS in turn authenticates the End User by their full username and password. Only those End Users authorised by the Customer to access the service should be able to establish a session to the Customer network.

The Customer RADIUS must support and use the attributes described below. IEFT RADIUS attributes only must be used. No Vendor Specific Attributes will be supported by the BT Wireless Broadband infrastructure. Customers may use VSAs between the Customer LNS and Customer RADIUS at their own discretion. BT Wireless Broadband devices will ignore any additional attributes returned by the Customer RADIUS and will still, if possible, establish the PPP session.

The Customer RADIUS server must conditionally or unconditionally comply with RFCs 2865^[7], 2866^[8], 2867^[9], 2868^[10] and 2869^[11]. It should be noted that the value of the Response Authenticator field in Access-Accept, Access-Reject and Access-Challenge packets will be constructed in the form:

`ResponseAuth=MD5 (Code+ID+Length+RequestAuth+Attributes+Secret)`

where + denotes concatenation, as stated in RFC2865^[7].

7.3.1 Access Request packet attributes

As part of the tunnel establishment process between the LAC and the Customer LNS, the BT LTS may send an Access Request to the Customer RADIUS. If required, the format of this Access Request packet is as follows:

Attribute Number	Attribute Name	Attribute Value
1	User-Name	user@domain
3	CHAP-Password	Password
4	NAS-IP-Address	BT LTS loopback address
5	NAS-Port	BT LTS logical port
6	Service-Type	(2) Framed
7	Framed-Protocol	(1) PPP
61	NAS-Port-Type	(5) Virtual

Table 1. Access Request packet attributes

7.3.2 Access Accept packet attributes

Attribute Number	Attribute Name	Attribute Value
6	Service-Type	(2) Framed (Optional)
7	Framed-Protocol	(1) PPP (Optional)
25	Class	String (Optional)
64	Tunnel-Type	(3) L2TP
65	Tunnel-Medium-Type	(1) IPv4
67	Tunnel-Server-Endpoint	LNS IP address (dotted decimal only)
69	Tunnel-Password	Password (Optional)
82	Tunnel-Assignment-ID	String (Optional – used for multiple tunnels between LTS and LNS)
83	Tunnel-Preference	Integer (Optional – used with Tunnel-Server-Endpoint)
90	Tunnel-Client-Auth-ID	Name (Optional – default can be configured on BT LTS)

Table 2. Access Accept packet attributes

7.4 RADIUS accounting

RADIUS accounting data will not be provided from the Service RADIUS server. Accounting information should be available to the Customer from their LNS if required.

8. References

[1]	IEEE 802.3	Standards for Local Area Networks: CSMA/CD Access Method
[2]	RFC791	Internet Protocol: DARPA Internet Program Protocol
[3]	RFC1661	The Point-to-Point Protocol (PPP)
[4]	RFC1994	PPP Challenge Handshake Protocol (CHAP)
[5]	RFC1877	PPP Internet Protocol Control Protocol Extensions for Name Server Addresses
[6]	RFC2516	A Method for Transmitting PPP Over Ethernet (PPPoE)
[7]	RFC2865	Remote Authentication Dial In User Service (RADIUS)
[8]	RFC2866	RADIUS Accounting
[9]	RFC2867	RADIUS Accounting Modifications for Tunnel Protocol Support
[10]	RFC2868	RADIUS Attributes for Tunnel Protocol Support
[11]	RFC2869	RADIUS Extensions
[12]	RFC2661	Layer Two Tunnelling Protocol (L2TP)

For information on where to obtain these referenced documents, please see the document sources list at <http://www.sinet.bt.com/docsources.htm>.

9. Abbreviations

Acronym	Expansions
ADSL/SDSL	Asymmetric/Symmetric Digital Subscriber Line
AU	Access Unit
BE	Best Effort service
BGP4	Border Gateway Protocol version 4
BT	British Telecom
CHAP	Challenge Handshake Authentication Protocol
CPE	Customers' Premises Equipment
DNS	Domain Name System/Server
IEEE	Institute of Electronic and Electrical Engineers
IETF	Internet Engineering Task Force
IP	Internet Protocol
IPCP	Internet Protocol Connection Protocol
IPv4	Internet Protocol Version 4
ISP	Independent Service Provider
L2TP	Layer 2 Tunnelling Protocol
LAC	L2TP Access Concentrator
LAN	Local Area Network
LC	Lucent Connector (Fibre Optic)
LCP	Link Control Protocol
LNS	L2TP Network Switch
LTS	Layer 2 Tunnelling Protocol (L2TP) Tunnel Switch
MAC	Media Access Control
MD5	Message Digest 5
MRU	Maximum Receive Unit
MTU	Maximum Transmission Unit
NTE	Network Termination Equipment
PC	Personal Computer
PPP	Point-to-Point Protocol
PPPoE	Point-to-Point Protocol over Ethernet
PSTN	Public Switched Telephone Network
RADIUS	Remote Authentication Dial In User Service
RFC	Request for Comment
RJ45	Registered Jack 45
SFP	Small Form Factor Pluggable
SIN	Supplier Information Note
SP	Service Provider
SU	Subscriber Unit
TCP	Transmission Control Protocol
VSA	Vendor-Specific Attribute
USB	Universal Serial Bus
UTP	Unshielded Twisted Pair

10. History

Issue	Date	Changes
Issue 1.0	17/11/05	First issue.

-END-

***WE WOULD BE GRATEFUL IF YOU WOULD SPEND A FEW MINUTES TO
COMPLETE AN ONLINE CUSTOMER SATISFACTION FORM AT
[HTTP://WWW.SINET.BT.COM/HAPPY.HTM](http://www.sinet.bt.com/happy.htm)***