



SIN 509

Issue 1.0
October 2011

Suppliers' Information Note

For The BT Network

BT Wholesale Broadband Connect (WBC) Fibre to the Premise (FTTP) Service & Interface Description

Each SIN is the copyright of British Telecommunications plc. Reproduction of the SIN is permitted only in its entirety, to disseminate information on the BT Network within your organisation. You must not edit or amend any SIN or reproduce extracts. You must not remove BT trade marks, notices, headings or copyright markings.

This document does not form a part of any contract with BT customers or suppliers.

Users of this document should not rely solely on the information in this document, but should carry out their own tests to satisfy themselves that terminal equipment will work with the BT network.

BT reserves the right to amend or replace any or all of the information in this document.

BT shall have no liability in contract, tort or otherwise for any loss or damage, howsoever arising from use of, or reliance upon, the information in this document by any person.

Due to technological limitations, a very small percentage of customer interfaces may not comply with some of the individual characteristics, which may be defined in this document.

Publication of this Suppliers' Information Note does not give or imply any licence to any intellectual property rights belonging to British Telecommunications plc or others. It is your sole responsibility to obtain any licences, permissions or consents which may be necessary if you choose to act on the information supplied in the SIN.

Those BT services marked ® indicates it is a registered trade mark of British Telecommunications plc.

Those BT services marked ™ indicates it is a trade mark of British Telecommunications plc.

This SIN is available in Portable Document Format (pdf) from: <http://www.sinet.bt.com>

Enquiries relating to this document should be directed to: help@sinet.bt.com

CONTENTS

1. INTRODUCTION.....	3
2. SERVICE OUTLINE.....	4
2.1 GENERAL	4
2.2 SERVICE AVAILABILITY AND TARIFFS	4
3. INTERFACE DESCRIPTIONS.....	4

3.1	GENERAL	4
3.2	INTERFACE PRESENTATION.....	4
3.3	ARCHITECTURE.....	5
3.4	END USER ACCESS.....	5
4.	REFERENCES.....	6
5.	ABBREVIATIONS	6
6.	HISTORY	8

FIGURES

FIGURE 1. WBC FTTC/P NETWORK ARCHITECTURE	5
---	---

1. Introduction

Supplier's Trial Information Note (SIN) 509 provides technical information on the trial of the BT Wholesale Broadband Connect (WBC) Fibre to the Premise (FTTP) service.

The information contained in this SIN relates to the trial of a potential service. The publication of this SIN does not commit BT to a commercial launch of this service, nor does it commit BT to the particular implementation described within this document. Please check with the <http://www.sinet.bt.com> site to ensure you have the latest version of this document.

This SIN should be read in conjunction with SIN 472 for the WBC service and SIN 477 & 506 for Openreach's Fibre to the Premise (FTTP) Generic Ethernet Access service.

Further information regarding the product can be obtained by contacting your company's BT Account Manager.

Contacts for further information can be found at <http://www.sinet.bt.com/usenum.htm>.

2. Service Outline

2.1 General

The WBC FTTP Service provides an End User (EU) Access service option as part of the overall WBC Service. Openreach provides the Generic Ethernet Access for an End User Access up to a point of handover in an exchange (which is not necessarily the same telephone exchange as for the EU's Public Switched Telephone Network exchange line (PSTN)) and WBC backhauls it on behalf of its Service Providers (SP's) to one of 20 WBC Interconnect Nodes.

2.2 Service Availability and Tariffs

The availability of WBC FTTP for an EU can be obtained from the Broadband Availability Checker, which can be found at;

https://www.btwholesale.com/pages/static/Community/Broadband_Community/Coverage/ADSL_Availability_Checker.html

3. Interface Descriptions

3.1 General

The WBC FTTP product will consume and use Openreach's Generic Ethernet Access over FTTP (GEA FTTP) product, part of the Openreach's Super-Fast Fibre Access (SFFA).

The WBC FTTP product will use an overlay of fibre infrastructure at sites with existing copper infrastructure and provides an alternative solution to WBC Fibre to the Cabinet (WBC FTTC). We do not intend to offer WBC FTTP and WBC FTTC from the same Primary Connection Point (PCP) – also commonly referred to as a cabinet district; however WBC FTTP and WBC FTTC will co-exist within some exchange areas.

WBC FTTP is available as a data-only or a data-and-voice service. Up to four data services will be available on one Optical Network Termination (ONT).

3.2 Interface presentation

The WBC FTTP product offers an active wholesale network connection from the Aggregation Point (AP) to the end user premise with Ethernet presentation at the End User's Network Interfaces. Communication Providers (CP's) will be able to provide their broadband services over this active network connection.

The WBC FTTP service is delivered on a single Virtual Local Area Network (VLAN) and is presented to the CP via the AP.

BT Wholesale will provide and maintain the WBC FTTP service. General information regarding this service can be found using the Openreach SIN477 and SIN506. This is the point of reference for CPs wanting to understand the technical configurations that they need to follow to interface with the GEA product until Openreach updates SIN477 and SIN506.

3.3 Architecture

The network architecture for GEA-FTTP is shown in figure 1 below. Until a Voice over NGA or alternative voice access solution is available, voice services will initially be provided (using either Openreach WLR or MPF products) over the existing copper network.

WBC FTTC / P Network Architecture

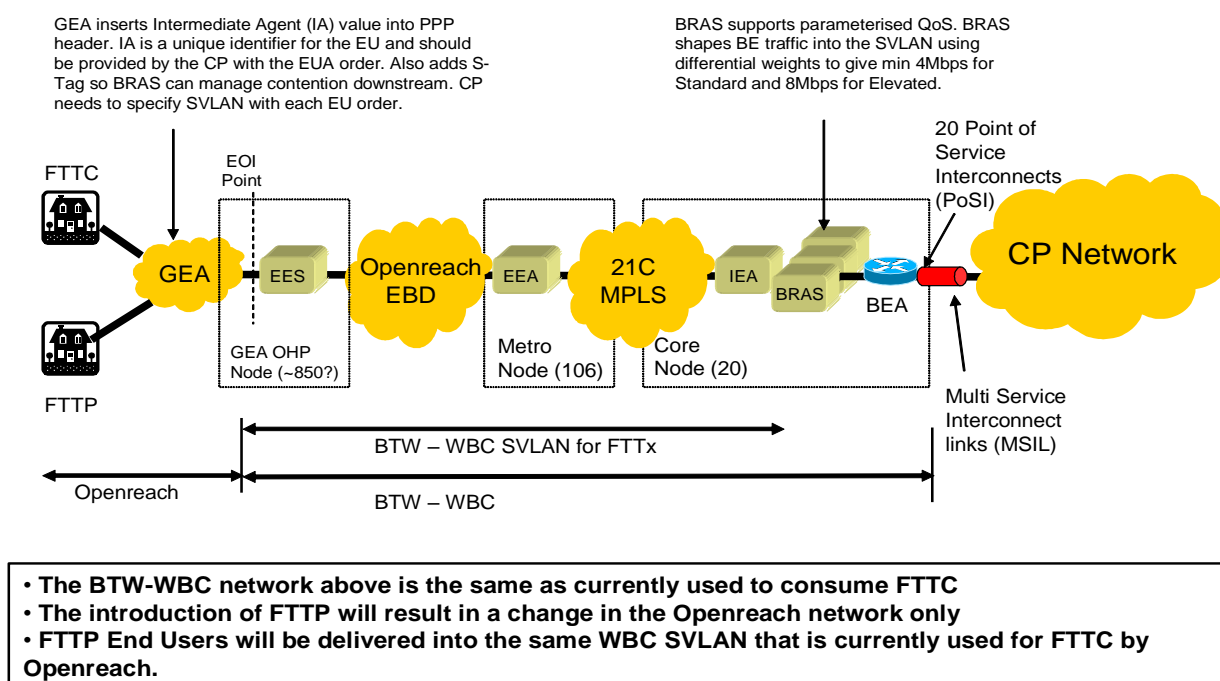

Figure 1. WBC FTTC/P Network Architecture

3.4 End User Access

The proposed WBC FTTP service is provided and assured on BT Wholesale’s eCo Plus service <https://www.btwholesale.com/pages/cmsjsps/Applications/Orders/EcoPlus.jsp>

Orders and faults can be submitted either via eCo Plus or via XML transactions. Full details of the ordering process are described in the Product Handbook that can be found at <https://www.btwholesale.com>.

An ONT device will terminate the fibre at the end user’s premise and needs to be fitted to a wall to avoid a fibre fracture. This is an active NTE which allows Openreach to monitor and test the service provided. The ONT must be within reach of a power supply and it is designed to remain connected to the power at all times. Please note that Openreach does not proactively react to alarms relating to power failure.

The ONT is owned by Openreach and represents the demarcation of the WBC FTTP product within the premise and is the point into which the CP will need to connect their own Customer Premises Equipment (CPE).

4. References

Suppliers Information Notes:

[1]	SIN 472	WBC SIN
[2]	SIN 477	FTTP Generic Ethernet Access Service & Interface Description
[3]	SIN 506	Fibre to the Premises (FTTP) Generic Ethernet Access, Service and Interface Description

For information on where to obtain these referenced documents, please see the document sources list at <http://www.sinet.bt.com/docsources.htm>.

5. Abbreviations

AP	Aggregation Point
BT	British Telecommunications Plc.
BEA	BEA switch
BRAS	Broadband Remote Access Server
CP	Communications Provider
CPE	Customer Premise Equipment
EBD	Ethernet Backhaul Direct
EEA	Ethernet Extension Access
EES	Ethernet Extension Service
EOI	Equivalence Of Input
EU	End User
FTTC	Fibre to the Cabinet
FTTP	Fibre to the Premise
GEA	Generic Ethernet Access
GEA OHP	Generic Ethernet Access Optical Hosting Point
IA	Intermediate Agent
IEA	Interconnect Ethernet Access
MPF	Metallic Path Facility
21C MPLS	21 Century Multi Protocol
MSIL	Multi Service Interconnect Link
NGA	Next Generation Access
NTE	Network Termination Equipment

ONT	Optical Network Termination device
PATS	Publicly Available Telephone Service
PCP	Primary Connection Point
POSI	Point Of Service Interconnect
PPP	Point-to-Point Protocol
PSTN	Public Switched Telephone Network
QOS	Quality Of Service
SFFA	Super-Fast Fibre Access
SIN	Suppliers' Information Note (BT Publication)
SP	Service Provider
SIN	Suppliers' Information Note (BT Publication)
SVLAN	Service Virtual Local Area Network
VLAN	Virtual Local Area Network
WBC	Wholesale Broadband Connect

6. History

Issue	Date	Changes
Issue 1.0	October 2011	First Issue

-END-